

# **FB BUTELINE™** PLUMBING SYSTEM

## Plumbing and Heating Installation Manual

September 2019

**THE**  
**UK'S FINEST**  
PLUMBING SYSTEM

**WRAS**  
APPROVED  
PRODUCT

**iphe**  
INDUSTRIAL  
ASSOCIATE

**CPS**  
CERTIFIED  
The City Certification  
SERVICE



0800 043 8883  
[www.buteline.com](http://www.buteline.com)



## Contents

---

Buteline and Its Commitment	1
The Buteline Plumbing System	2
Why Plumbers Use the Buteline Plumbing System	3
Buteline PB-1 Plumbing System - 10mm, 16mm, 22mm & 28mm Range	4-8
Buteline Fittings	9
Buteline Polybutene-1 Barrier Pipe	10
Buteline Clamp Tools	11
Recalibration Instructions for ProClamp Tools	12
Adjustment Instructions for 28mm Clamp Tool	13
Installation Demonstration for BFR Non-Adjustable Clamp Tools	14
Installation Demonstration for ProClamp Tools & 28mm Clamp Tool	15
Installation Demonstration for 10mm	16
Installation Guide	17-19
Use Only The Complete Buteline System	20
Storage and Handling	21
Feeding Buteline PB-1 Pipe through Timber Frames, Metal Studwork or Brickwork	21
Bending Radius & Pipe Clipping	22
Buteline Polymer Threaded Connections & Tap Connectors	23
Connecting to Copper Solder Tails	24-25
Connecting to Copper Compression Fittings	26-27
Installing Buteline in Concrete / Floor Screed	28
UV Exposure & Freezing Conditions	29
Fire Protection & Thermal Conductivity	30
Buteline Internal Bore Sizes	30
Pipe Wall Thickness	31-32
Flow Rates at Specific Velocities for PB-1 Pipe	32
Working Temperature and Pressure	33
Pipe Pressure Head Loss for Polybutene-1 Pipe	34
Solar Hot Water	35
Hot Water Installations	35
Use with Oil Fired Boilers	36
Use with Re-circulating Continuously Operating Ring Main Hot Water Systems	36
Re-circulated Hot Water Systems Flow Chart	37
Bute-1 Installation Guide	38-39
Testing Your Installation	40
Other Uses For The Buteline Plumbing System	40
Use For Central Heating Applications	41
Frequently Asked Questions	42-45
Definition Of Terms	46-47
Pressure Conversion Chart	48
Project References	50-51
The Buteline Guarantee	53

## Buteline And Its Commitment

The Buteline professional Polybutene-1 (PB-1) Plumbing System has won world acclaim for innovation and advanced design. The commitment to excellence continues to be evident with the products shipped from Buteline's manufacturing facility in Auckland, New Zealand.

Changing times demand new materials and new ideas!

The challenges encountered in the design and manufacture of the "plumbing system of the future" are met by the dedicated team at Buteline in a professional and dynamic manner.

Buteline has installed in-house test equipment to give both quality assurance and quality control of production. These facilities combined with a strong commitment to continuing research and development will ensure Buteline remain leaders in PB-1 technology. Our engineers and technical team accept the challenge for future product development.

The Buteline Plumbing System meets all the requirements of the British Standard - BS 7291:2002 and is a WRAS approved product.

***The Plumbing System for Professional Plumbers .***



*This version of the Plumbers Manual supersedes all previous versions of the manual and the information therein.*

## The Buteline Plumbing System

---

Buteline has developed a total solution to the need for a safe, integrated and easy to use potable water plumbing and heating system.

The resultant PB-1 system is designed specifically for professional plumbers and has proven to be high quality and economical.

It is strongly recommended that tradesmen use Buteline's total system, i.e. Buteline clamp tools, Buteline PB-1 pipe and clips, and Buteline fittings, to ensure total compatibility of installations. When installed in accordance with recommendations contained herein, the complete system is fully guaranteed by Buteline (see page 53).



## Why Plumbers Use The Buteline Plumbing System

- ✓ The Buteline PB-1 System has a design concept incorporating factory fitted clamp rings which ensures high productivity.
- ✓ The Buteline standard clamp tools have been designed and engineered for ease of use, to give long life and a professional result every time.
- ✓ The Buteline PB-1 System includes an extensive range of quality useful fittings, and is readily available from appointed stockists. Call 0800 043 8883 for your nearest stockist.
- ✓ The Buteline PB-1 System is approved by WRAS for use in potable hot and cold water installations
- ✓ The Buteline PB-1 System is competitively priced.
- ✓ The Buteline factory fitted metal sleeve provides the strongest reinforced joint available.
- ✓ The Buteline PB-1 System eliminates water hammer noise.
- ✓ The Buteline PB-1 System has been designed specifically for use by tradesmen.
- ✓ Buteline fittings will not twist once clamped.
- ✓ Slim-line design.
- ✓ Guaranteed security for 25 years.



## Buteline PB-1 Plumbing System



### EQUAL TEES

**BT10** - 10mm x 10mm x 10mm  
**BT16** - 16mm x 16mm x 16mm  
**BT22** - 22mm x 22mm x 22mm  
**BT28** - 28mm x 28mm x 28mm



### REDUCING TEES

**BRT020** - 10mm x 22mm x 10mm  
**BRT022** - 10mm x 22mm x 22mm  
**BRT110** - 16mm x 16mm x 10mm  
**BRT112** - 16mm x 16mm x 22mm  
**BRT220** - 22mm x 22mm x 10mm  
**BRT211** - 22mm x 16mm x 16mm  
**BRT212** - 22mm x 16mm x 22mm  
**BRT221** - 22mm x 22mm x 16mm  
**BRT822** - 28mm x 22mm x 22mm  
**BRT881** - 28mm x 28mm x 16mm  
**BRT882** - 28mm x 28mm x 22mm  
**BRT828** - 28mm x 22mm x 28mm



### IN LINE COPPER TO PB PIPE TEE

**BTC16** - 15mm Cu x 15mm Cu x 16mm



### INLINE COUPLINGS

**BS10** - 10mm x 10mm  
**BS16** - 16mm x 16mm  
**BS22** - 22mm x 22mm  
**BS28** - 28mm x 28mm

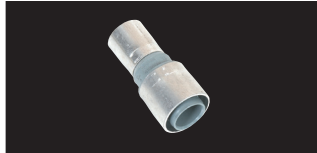

### REDUCING COUPLINGS

**BS1610** - 16mm x 10mm  
**BS2210** - 22mm x 10mm  
**BS2216** - 22mm x 16mm  
**BS2822** - 28mm x 22mm



### MALE ADAPTORS

**BMP16** - 1/2" BSPT x 16mm  
**BM316** - 3/4" BSPT x 16mm  
**BM32** - 3/4" BSPT x 22mm  
**BM328** - 3/4" BSPT x 28mm  
**BM128** - 1" BSPT x 28mm



### CHROME RADIATOR VALVE CONNECTOR

**BF16C** - 1/2" BSP x 16mm



### CHROME ELBOW RADIATOR VALVE CONNECTOR

**BFPE10C** - 10mm Bute x 10mm Cu or Pushfit



### CHROME EXTENDED ELBOW

**BRE316C** - 300mm 15mm CU x 16mm Bute

## 10mm, 16mm, 22mm and 28mm Range



### PB PIPE TEE TO 15MM COPPER

**BTKP16** - 16mm x 16mm x 15mm Cu



### EQUAL CROSSES

**BCX40** - 16mm x 16mm x 16mm x 16mm

**BCX48** - 22mm x 22mm x 22mm x 22mm



### REDUCING CROSSES

**BCX42** - 22mm x 22mm x 22mm x 16mm

**BCX44** - 22mm x 16mm x 22mm x 16mm

**BCX46** - 22mm x 16mm x 16mm x 16mm



### BRASS MALE ADAPTORS

**BBM16** - 1/2" BSPT x 16mm

**BBM32** - 3/4" BSPT x 22mm



### MALE BARREL NIPPLES

**B421** - 1/2" BSPT x 1/2" BSPT

**B422** - 1/2" BSPT x 3/4" BSPT

**B423** - 3/4" BSPT x 3/4" BSPT



### TAP CONNECTORS

**BF16** - 1/2" BSP x 16mm

**BF31** - 3/4" BSP x 16mm

**BF32** - 3/4" BSP x 22mm

**BSF328** - 3/4" BSP x 28mm

**BSF128** - 1" BSP x 28mm

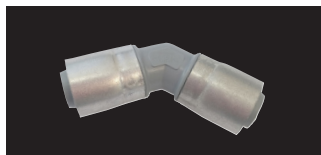

### 45 DEGREE ELBOWS

**BE4516** - 16mm x 16mm

**BE4522** - 22mm x 22mm

**BE4528** - 28mm x 28mm



### EQUAL ELBOWS

**BE10** - 10mm x 10mm

**BE16** - 16mm x 16mm

**BE22** - 22mm x 22mm

**BE28** - 28mm x 28mm



### REDUCING ELBOWS

**BER282** - 28mm x 22mm

# Buteline PB-1 Plumbing System



## MALE ELBOWS

- BMEP16** - 1/2" BSPT x 16mm
- BME32** - 3/4" BSPT x 22mm
- BME328** - 3/4" BSPT x 28mm
- BME128** - 1" BSPT x 28mm



## MALE/FEMALE EXTENDED ELBOW

- BMF60** - Male 1/2" BSP x Female 1/2" BSP



## ELBOW TAP CONNECTORS

- BEF16** - 1/2" BSP x 16mm
- BEF32** - 3/4" BSP x 22mm
- BEF328** - 3/4" BSP x 28mm
- BEF128** - 1" BSP x 28mm



## COMPRESSION FITTINGS

- BMC16** - 16mm Bute PB x 15mm Cu
- BMC21** - 16mm Bute PB x 22mm Cu
- BMC22** - 22mm Bute PB x 22mm Cu



## TRANSITION FITTINGS

- BFP1610** - Brass 16mm Bute x 10mm Cu or Pushfit
- BP1615** - Plastic 16mm Bute x 15mm Cu or Pushfit
- BP2222** - Plastic 22mm Bute x 22mm Cu or Pushfit
- BCT1510** - 15 Cu to 10mm Bute



## ELBOWED PUSHFIT TRANSITION FITTINGS

- BPE1615** - 16mm Bute x 15mm Pushfit
- BPE2222** - 22mm Bute x 22mm Pushfit

## COMPRESSION / ISOLATION TRANSITION

- BCT1615** - 16mm Bute to 15mm compression



## MALE BACK PLATE ELBOWS

- BWM16** - 1/2" BSP x 16mm x 65mm
- BWM100** - 1/2" BSP x 16mm x 100mm



## HOSE PLATES

- BHP16** - 1/2" BSP x 16mm
- BHP22** - 3/4" BSP x 22mm

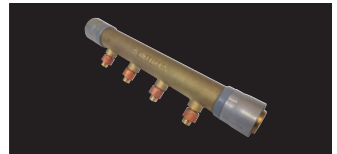

## HEATING MANIFOLDS

- BMF310** - 22mm inlet, 3 x 10mm outlet
- BMF410** - 22mm inlet, 4 x 10mm outlet
- BMF316** - 22mm inlet, 3 x 16mm outlet
- BMF416** - 22mm inlet, 4 x 16mm outlet

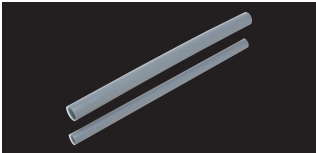

## PB-I BARRIER PIPES

### (CUT LENGTHS)

- BPL316** - 16mm x 3m
- BPL322** - 22mm x 3m
- BPL328** - 28mm x 3m



## PB-I BARRIER PIPES

- BPC210** - 10mm x 25m
- BPC510** - 10mm x 50m
- BPC10** - 10mm x 100m
- BPC26** - 16mm x 25m
- BPC56** - 16mm x 50m
- BPC106** - 16mm x 100m
- BPC206** - 16mm x 200m
- BPC22** - 22mm x 25m
- BPC52** - 22mm x 50m
- BPC28** - 28mm x 25m
- BPC58** - 28mm x 50m



## NAILED PIPE CLIPS

- BC10** - 10mm
- BC16** - 16mm
- BC22** - 22mm
- BC28** - 28mm



## 10mm, 16mm, 22mm and 28mm Range



### CHROME ELBOW TAP CONNECTOR

**BEF16C** - 1/2" BSP x 16mm

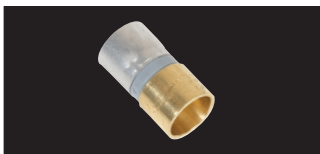

### FEMALE SOLDERING TAILS

**BFB16** - 15mm Cu x 16mm Bute  
**BFB22** - 22mm Cu x 22mm Bute  
**BFB28** - 28mm Cu x 28mm Bute



### ELBOWED FEMALE SOLDERING TAILS

**BFBE16** - 15mm Cu x 16mm Bute  
**BFBE22** - 22mm Cu x 22mm Bute



### BUTE1

**Adjustable 1/2" BSP Male Wall Elbow**  
**BUTE1** - 1/2" BSP x 16mm x 70mm  
 Pack includes 2 adjustable male elbows, 1 red end cap, 1 blue end cap and 1 metal fixing brace



### LUGGED ELBOWS

**BLE76** - 1/2" BSPT x 16mm x 70mm  
**BLE106** - 1/2" BSPT x 16mm x 100mm



### FEMALE BACK PLATE ELBOWS

**BEW16** - 1/2" BSP x 16mm  
**BEW22** - 3/4" BSP x 22mm  
**BEW31** - 3/4" BSP x 16mm



### TEST PLUG

**BPH15** - 1/2" BSPT



### EXTENDED TEST PLUG

**BP15** - 1/2" BSP Extended



### PIPE END PLUGS

**BPG10** - 10mm  
**BPG16** - 16mm  
**BPG22** - 22mm  
**BPG28** - 28mm



### INTERLOCKABLE HINGED PIPE CLIPS

Can be connected together to make multiple clips  
**BCH16** - 16mm  
**BCH22** - 22mm  
**BCH28** - 28mm



### STANDARD CLAMP TOOLS

**BFR16** - 16mm  
**BFR22** - 22mm  
**BFR28** - 28mm

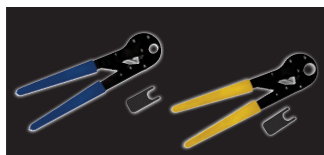

### PROCLAMP TOOLS

**PRO16** - 16mm  
**PRO22** - 22mm  
 Includes checking gauge.

## Buteline PB-1 Plumbing System

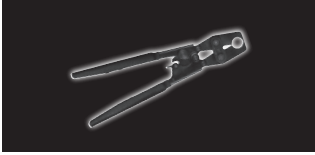

### MINI CLAMP TOOL

**BMT10** - 10mm



### ELECTRIC CLAMP TOOL AND JAWS

**ET01** - Boxed kit with electric clamp tool, battery and set of 3 jaws (as below)

**ETJ16** - 16mm jaws

**ETJ22** - 22mm jaws

**ETJ28** - 28mm jaws

Jaws for the electric tool are also available individually for purchase.



### BUTE TOOL BELT

**BTB10** - Designed to fit your Bute ProClamp tools, Bute fittings, pipe cutter, tape measure, hammer, pencil and ruler.



### PIPE CUTTER

**BPC30** - Spring loaded



### RADIATOR PIPE GUIDE & SEAL (BUILT IN)

**BGRS** - Part L Compliant. Provides a 'kink free', air tight, central location point for exit of 10mm pipe from internal walls



### RADIATOR PIPE GUIDE & SEAL (FACE FIX)

**BGRSF** - Part L Compliant. Provides a 'kink free', air tight, central location point for exit of 10mm pipe from internal walls



### CLAMP RINGS

**BCR10** - 10mm Copper Clamp Ring

**BCR10C** - 10mm Chrome Effect Clamp Ring

For use with 10mm Microbore System



### BUTE GETS YOU GOING PACK

**GGPI** - 2 standard clamp tools (16mm and 22mm), a pipe cutter and a selection of the most popular fittings.



### BUTE PRO STARTER PACK

**BPP10** - 2 ProClamp Tools (PRO16 and PRO22), a pipe cutter and a selection of the most popular fittings.

For the latest product news and updates, visit [www.buteline.co.uk](http://www.buteline.co.uk) or call 0800 043 8883 and request more information and the latest version of this Plumbing & Heating Installation Manual.

## Buteline Fittings

Buteline have developed an extensive range of quality fittings which have complete compatibility with Buteline Polybutene-1 pipe.

The annealed protective metal sleeve is precisely attached to each fitting during production and is designed to provide a unique metal reinforced joint. Users of Buteline fittings will therefore find the total concept much quicker and more economical than other available systems.

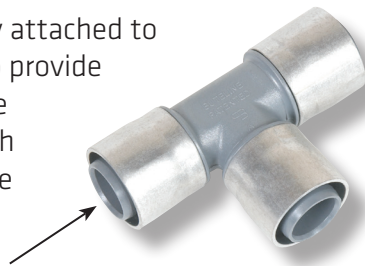

No o-rings or pipe inserts are required

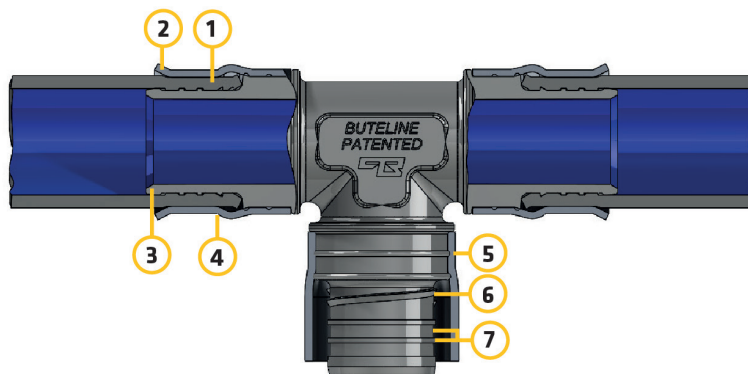

### 1 WIDE FORGED CLAMP

Minimum working stress applied (approx. 0.5 ton per sq. in.) allowing pipe material to “flow” into insert tail grooves.

### 2 2mm WIDE FLARE

No stress from clamping transmitted to insert tail or pipe at end of fitting. End of metal sleeve cannot impinge into pipe, even in bending.

### 3 TAPERED ENTRY, SMOOTH BORE

Minimise resistance to water flow.

### 4 METAL REINFORCING SLEEVE

Guarantees no stress break in this critical area.

### 5 FULL LENGTH ALUMINIUM SUPPORT

Provides additional rigidity and resistance to pull-off. Seals against dirt and moisture.

### 6 SUREFIT HELIX

Patented design feature prevents pipe from falling off sleeve, ensures precise positioning.

### 7 SEALING RIBS

Narrow lands with wide grooves, ensure clamp stress is transferred into the pipe joint efficiently.

## Buteline Polybutene-1 Barrier Pipe

Buteline Polybutene-1 pipe is produced in 10mm, 16mm, 22mm and 28mm sizes and supplied in the following forms:

Size (mm)	Lengths		Coils		
	3m	25m	50m	100m	200m
10		✓	✓	✓	
16	✓	✓	✓	✓	✓
22	✓	✓	✓		
28	✓	✓	✓		

It is manufactured to meet the exacting British Standard BS 7291:2002 and is fully WRAS Approved.

Flexible, tough and non-corrosive, Buteline Polybutene-1 pipe is approved for use on both hot and cold potable water services as well as heating requirements and can withstand high temperatures and pressures (see page 33).

In order to make the Polybutene-1 pipes impervious to oxygen penetration, for the protection of metallic components of circulated water-heating systems (radiators, boilers etc.), Buteline PB-1 pipe incorporates a thin layer of Ethylene Vinyl Alcohol (EVOH) to prevent oxygen transfer from the external air to the water carried within the pipe. The EVOH layer is applied during the manufacture of the pipe by co-extruding the EVOH, together with a layer of specially formulated adhesive.

Because of its excellent oxygen and hydrocarbon barrier properties, EVOH is commonly used as a barrier layer on plumbing pipes, food-packaging materials and as a liner in automotive plastic petrol tanks. EVOH will maintain its barrier properties over a very wide temperature range, so it is particularly suited to protecting all plumbing pipes from oxygen infiltration.

## Buteline Clamp Tools

Buteline have engineered their clamp tool to ensure a simple, controlled, accurate joint every time. They have a “head” design which permits easy access and alignment. The Buteline clamp tool is available in four sizes to suit 10mm, 16mm, 22mm and 28mm Buteline Polybutene-1 pipe and fittings.

Buteline have developed an alternative tool to the standard clamp tool, the ProClamp tools (pictured below) for 16mm and 22mm.

*(Buteline Mini Tools and ProClamp Tools come supplied with a 12 month guarantee from date of purchase.)*



Standard Clamp Tools

Mini Tool

ProClamp Tools

Electric Clamp Tool  
& Bute Jaws

### Servicing Your Clamp Tool

Buteline PB-1 Clamp Tools are a very important part of the system. They are extremely robust and designed to perform up to a consistent high standard for many years. Service your clamp tool by cleaning and oiling moving parts regularly. ProClamp and Mini Tools may require periodic recalibration (see pages 12-13).

## Recalibration Instructions for ProClamp Tools

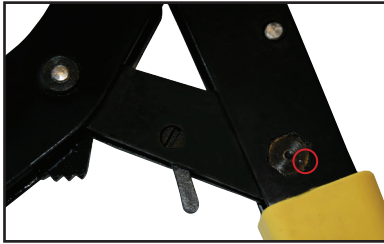

1. Identify the position of the adjuster cam by locating the dot on the hexagonal end of the cam.

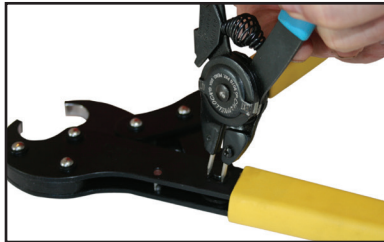

2. Turn the tool over and remove the circlip securing the adjuster cam.



3. Retain the circlip for replacement after adjustment.

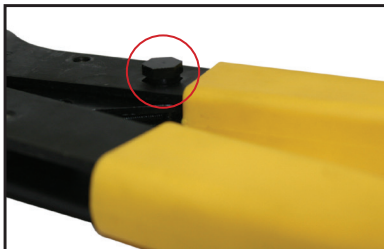

4. Push the adjuster cam out from the circlip side until the hexagon head of the cam disengages from the handle, and turn the cam anticlockwise, so that it is moved around 1 flat of the hexagon.

5. Push the hexagonal head of the cam back into the handle and replace the circlip to retain the adjuster cam.

*NOTE: Maximum adjustment is achieved when the adjusting cam is rotated 180° in one direction and the maximum amount of times a ProClamp tool can be recalibrated is 5.*

## Adjustment Instructions for 28mm Clamp Tool



1. Remove the screw and the locking plate.



2. Rotate the adjuster in the direction of the arrow shown on the plate by 1 notch.



3. Replace the locking plate and the screw.

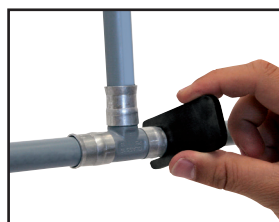

4. Check for correct clamp width.

## Installation Demonstration for BFR Non-Adjustable 16mm & 22mm Clamp Tools

---



1. Cut pipe to length squarely and cleanly using an approved plastic pipe cutter.

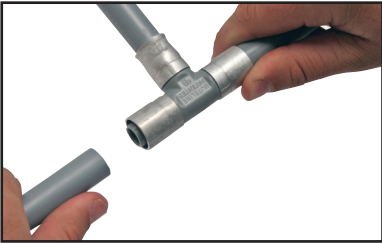

2. Insert the pipe into the fitting. Ensure you push the pipe all the way (15mm) with a slight twist to 'SureFit' onto the shoulder of the fitting, up to the next indicator line of the same size.



3. *Clamp-Hold-Release*

Clamp approximately 2mm in from the end of the fitting, close the tool handles completely to the stops provided, and hold firmly for around 2 seconds then release.



4. The process of installing the system is clean and quick, leaving a watertight mechanical joint.



## Installation Demonstration for ProClamp Tools & 28mm Clamp Tool



1. Cut pipe to length squarely and cleanly using an approved plastic pipe cutter.

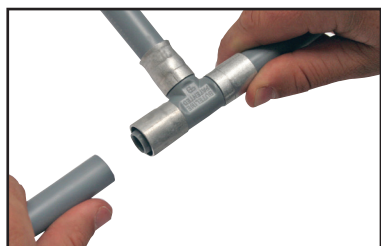

2. Insert the pipe into the fitting. Ensure you push the pipe all the way (15mm) with a slight twist to 'SureFit' onto the shoulder of the fitting, up to the next indicator line of the same size.

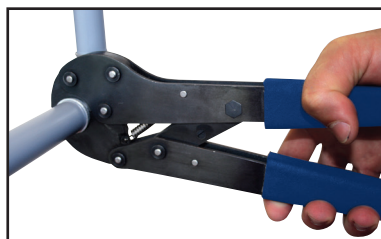

### *Clamp-Hold-Release*

3. Clamp once only, approximately 2mm in from the end of the clamp ring. Close the clamp tool handles completely, holding firmly for around 2 seconds and then the tool will release.

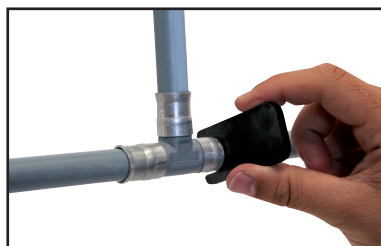

4. Use the gauge provided to check that the full clamp force has been achieved. If the gauge does not pass over the ring, the ring is under-clamped. It is important that the gauge passes over the clamp ring.

## Installation Demonstration for 10mm



1. Cut pipe to length squarely and cleanly using an approved plastic pipe cutter.

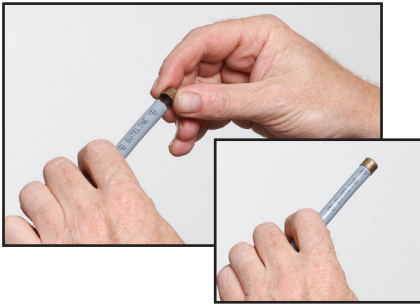

2. Slide the clamp ring onto the end of the pipe until the step in the ring comes against the end of the pipe.

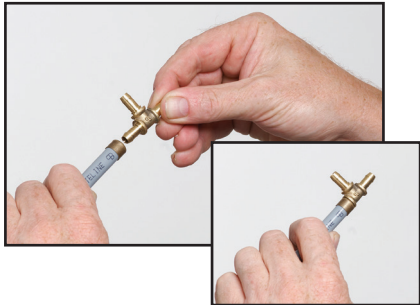

3. Push the tail of the fitting into the end of the pipe so that the shoulder of the fitting butts up against the end of the pipe. Ensure that the fitting is correctly aligned to allow all the connections to be made properly.

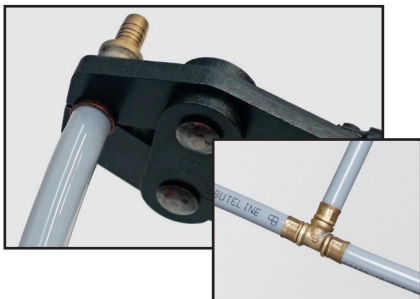

4. Position the clamp tool squarely over the clamp ring with the jaws approximately 1mm from the outside end of the clamp ring.

Close the clamp tool handles completely until the jaws touch and hold closed, then release.

## Installation Guide

---

Treat Buteline Polybutene-1 installations in a tradesman-like manner. Use the complete “Buteline” system – clamp tools, pipe, fittings, etc.

### Preparation Of Pipe

- (a) Pipe must be clean and free from grease or any other contamination.
- (b) Pipe must have no kinks, buckled sections, deep scores, etc.
- (c) When measuring, allow 15mm of pipe for each fitting or cut against pre-printed insertion guide.
- (d) Allow enough length for expansion / contraction (minimum 10mm per metre).
- (e) Cut the pipe to length squarely and cleanly using only approved pipe cutters.

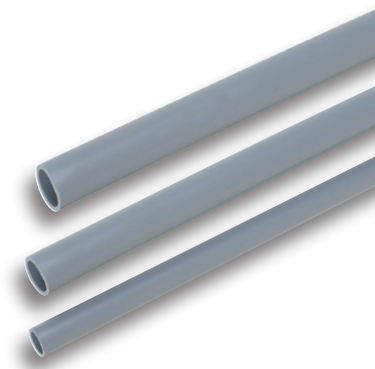

## Position Of Fittings

- (a) Pre-position fittings correctly on the pipe to achieve alignment with all other pipework prior to final clamping.

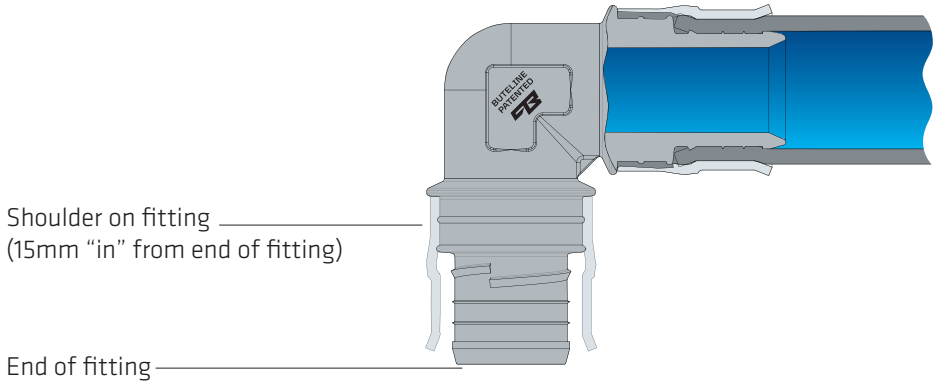

- (b) Fully insert (push home to shoulder) with a slight twist to SureFit the pipe into Buteline fittings, up to the next visible indicator line of the same size to ensure full engagement of pipe into the fitting.

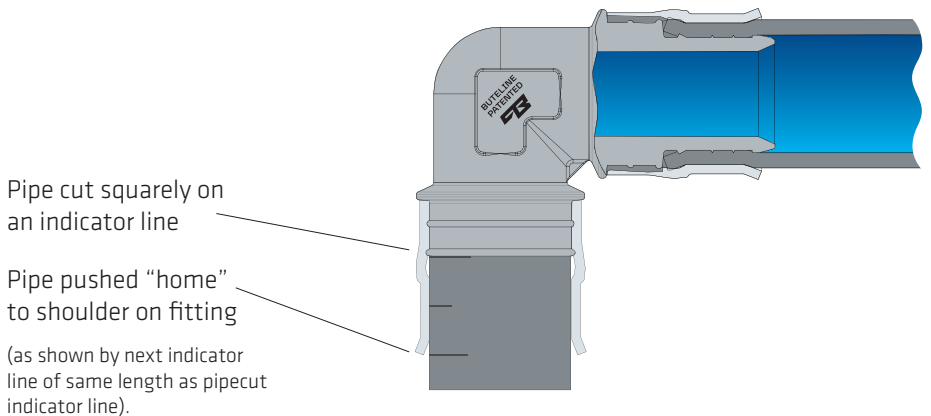

## Clamping Buteline Fittings

- (a) Position the Buteline clamp tool squarely and approximately 2mm in from the end of the factory fitted reinforcing clamp ring.

Correct Clamp Tool Position

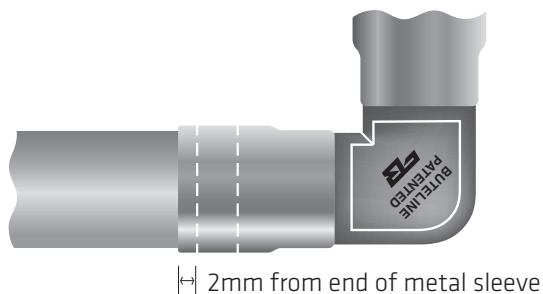

- (b) Close clamp tool handles completely (to the stops provided), hold fully closed for approximately 2 seconds, then release.
- (c) A good clamp will produce a “flare” at the end of the reinforcing ring. The “flare” shows that the full clamp width has been applied to the joint - and the designed result achieved. (It is important that a full clamp width is achieved).

Correct Appearance Of Best Joint

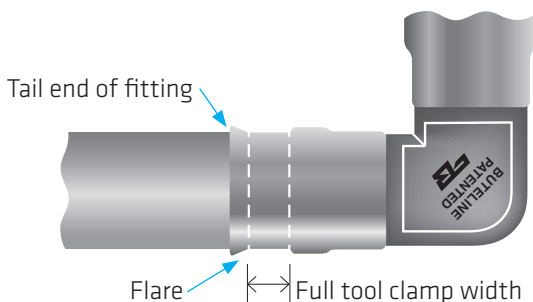

### INSTALLER NOTE:

*Failing to install Buteline fittings as advised in this Installation Manual voids all warranties. If joints are not made as per this manual, please remove and replace with a new fitting.*

- (d) Be methodical – ensure you clamp all fittings on the job, and do not double clamp.

## Use Only The Complete Buteline System

---

The use of the complete Buteline System (Buteline pipe, Buteline fittings, the Buteline clamp tool) is imperative for a number of reasons:

- ✓ Buteline offers a warranty **ONLY** when the complete Buteline System (BUTELINE PIPE, BUTELINE FITTINGS, BUTELINE TOOLS) is used.
- ✓ Buteline pipe is made to specific tolerances for use with the Buteline fittings to give a strong, leak-proof and PERMANENT joint every time. Only Buteline pipe is manufactured to the exacting standard demanded by the Buteline range of fittings.
- ✓ The exclusive use of Buteline components ensure a PROFESSIONAL TRADESMAN-LIKE job every time.

The complete Buteline Plumbing System offers the plumber many advantages, including:

- ✓ The Buteline clamping method has proven to be one of the fastest, most reliable PB-1 plumbing systems available.
- ✓ Buteline produces an extensive range of useful and innovative fittings.
- ✓ Buteline's total commitment and total dedication to the plumbing industry. Buteline will always be the leader in Polybutene-1 plumbing systems.
- ✓ Buteline's plumbing system is designed for the professional plumber, and offers security without additional parts such as O-rings and pipe inserts.

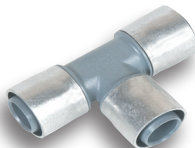

## Storage and Handling

---

- (a) Store fittings so that they cannot be damaged by heavy tools, etc. It is a good idea to have a tool box to carry the large range of fittings available.
- (b) Take care to keep the Buteline Plumbing System away from flux, chemicals, solvents, cements, oxidising agents or petroleum products.
- (c) Store the Buteline system away from direct sunlight and high temperature sources (e.g: heaters, boilers, gas / central heating / appliance vents).

## “Feeding” Buteline PB-1 Pipe Through Timber Frames, Metal Studwork or Brickwork

---

- (a) “Pipe sleeves” and bored holes should be large enough to allow free movement of Buteline PB-1 pipe.

Minimum Hole Sizes:

Use 12mm drills for – 10mm pipe

Use 18mm drills for – 16mm pipe

Use 24mm drills for – 22mm pipe

Use 32mm drills for – 28mm pipe

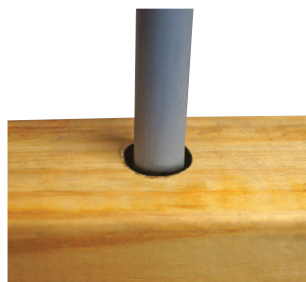

- (b) Larger holes may be required to ease pipe through if changing direction.
- (c) Use of silicone in the holes is not required.
- (d) When feeding pipe through metal studwork, concrete or brickwork, protective sleeves or grommets **MUST** be used to protect against abrasion.

## Bending Radius

Buteline Polybutene-1 pipe should be installed ensuring any bending radius is at least 10 times the outside diameter of the pipe.

Sharp bends should be made with appropriate fittings.

Pipe Size	Minimum Bending Radius
10mm (O.D. 10mm) (Type 10 Class 16)	100mm
16mm (O.D. 16mm) (Type 18 Class 16)	160mm
22mm (O.D. 22mm) (Type 22 Class 16)	220mm
28mm (O.D. 28mm) (Type 28 Class 16)	280mm

## Pipe Clipping

There are 2 types of Buteline pipe clips available:



Nailed pipe clip



Interlockable hinged pipe clip

- (a) Remember that Buteline PB-1 pipe is flexible but must not be “anchored tightly” between two points.
- (b) Pipes unsupported by clips are unsightly and can be damaged.

Maximum spacing of clips (metres)		
PB-1 Pipe	Horizontal or graded pipes	Vertical pipes
Type 10mm & Type 16mm	0.60	1.2
Type 22mm	0.70	1.4
Type 28mm	0.75	1.5



## Buteline Polymer Threaded Connections

---

- (a) It is essential to use (PTFE) pipe thread tape (not hemp) - use a small amount and wrap correctly onto male thread connectors (e.g: BMP16, BM316 etc) to ensure an adequate protection against leaking and contact with brass or galvanised material.
- (b) Avoid using liquid thread sealer compounds on Buteline polymer threaded fittings.
- (c) **DO NOT OVERTIGHTEN AS THREADS ARE TAPERED** and therefore will tighten with less turns compared to male parallel threads.

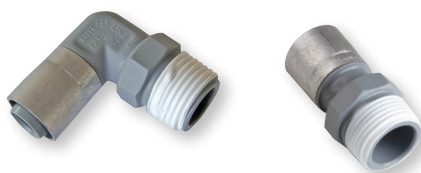

## Buteline Tap Connectors

---

- (a) Ensure that when using tap connectors, the shoulder is presented squarely to a flat machined face before tightening. This avoids crossed threads and ensures a seal. No (PTFE) pipe thread tape or sealant required.

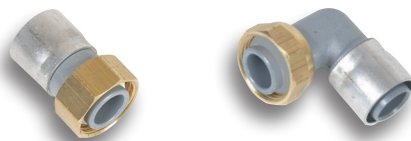

- (b) When connecting copper pipe to Buteline fittings (BTC16, BTKP16 etc.), use only a brass or copper olive - there is no need for hemp.
- (c) When installing all male or female threaded fittings, best practice is to fit & tighten the threaded end of the fitting PRIOR to clamping the pipe onto the tail of the fitting.

## Connecting to Copper Solder Tails

---



Before commencing any work involving heat processes, be sure to check that hot work is permitted.

1. Cut the copper pipe to length, ensuring the end is square. Clean, and apply flux ready for soldering.



2. Slide the solder fitting socket onto the copper pipe, ensuring that the aluminium and plastic clamp ring assembly has been removed.



3. Using suitable lead-free solder, make a solder joint between the fitting and the copper pipe.



4. AFTER the solder joint has COOLED, slide the aluminium clamp ring assembly onto the PB tail of the fitting, ensuring it goes fully up to the fitting shoulder.



5. Simply insert the PB pipe into the Buteline fitting and push fully home to the shoulder of the fitting.



6. *Clamp - Hold - Release*

- Clamp the Buteline fitting, using ONLY the Buteline clamp tool.
- Position the Buteline clamp tool squarely, approximately 2mm in from the end of the clamp ring.
- Close handles to stops, holding in the tightly closed position for around 2 seconds to ensure that the flow of material is performed. Open and remove the tool.



7. Finished.

- The process is complete!
- Installing the Buteline System is quick and secure and always provides a visual indicator of joint completion.

## Connecting to Copper Compression Fittings

---



1. Cut copper pipe to length, ensuring the end is square and free from burrs.



2. Slide the compression fitting onto the copper pipe, ensuring that the nut and olive are in place.



3. Tighten the compression fitting.



4. Insert the PB pipe fully up to the shoulder of the fitting and clamp using the Buteline clamp tool.

- Position the Buteline clamp tool squarely, approximately 2mm in from the end of the clamp ring.
- Close handles to stops, hold in the tightly closed position for around 2 seconds to ensure that the flow of material is performed. Open and remove the tool.



5. Finished.

- The process is complete!
- Installing the Buteline System is quick and secure and always provides a visual indicator of joint completion.

**NOTE:**

*AS YOU CAN SEE, THE PROCESS OF USING THE BUTELINE PLUMBING SYSTEM IS QUICK, SIMPLE AND HIGHLY EFFICIENT.*

## Installing Buteline in Concrete / Floor Screed

---

- (a) Use a pipe sleeve when burying Buteline PB-1 in concrete.  
Pipe sleeves should be large enough to allow free movement due to expansion & contraction.
  
- (b) A pipe sleeve is not required when installing an underfloor heating system (refer to manufacturer). If joints are necessary please refer to (c) below.
  
- (c) Where joints may come into contact with cement, lime or soil it is essential that the aluminium rings are completely wrapped using self amalgamating tape, PVC insulation tape or similar to protect the aluminium.

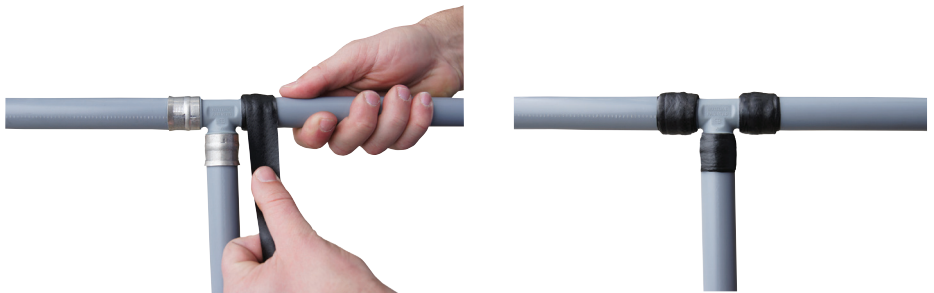

## UV Exposure

---

The Buteline System should be adequately protected against exposure to direct sunlight when located (either vertically or horizontally) on the exterior of a building, either using lagging or water-based paint.

## Freezing Conditions

---

Buteline PB-1 pipe is the best choice for water reticulation in climates where freezing conditions are possible.

Buteline PB-1 pipe will absorb the expansion of frozen water within itself and will absorb the additional expansion created by the water freezing inside a rigid fitting and expanding into the pipe, without splitting due to its flexible nature.

Minimise the problem by taking the following precautions where freezing conditions may apply:

- ✓ Make sure that any metal pipe to PB-1 pipe joints are made in a non-freezing area.
- ✓ Ensure 150mm between fittings so that ice expansion from a rigid pipe or joints can be absorbed by the PB-1 pipe.
- ✓ Bury PB-1 pipe where practical.
- ✓ Insulate PB-1 pipe where freezing conditions may prevail.
- ✓ Avoid placing PB-1 pipework within 'polar-facing' walls, where practical.

## Fire Protection

---

In tests performed at Springborn Laboratories in Enfield, Connecticut, Polybutylene-1 met the requirements of the Underwriters Laboratories test, regarding its fire resistance, and was classified as material UL94HB.

Where Buteline PB-1 penetrates fire resistant barriers, it must be installed to ensure the fire resistant integrity of the building is maintained (refer to local building codes).

## Thermal Conductivity

---

The thermal conductivity of copper is 400W/m/°C, compared to that of Polybutene-1, which is 0.217 W/m/°C. Copper is more than 1,800 times more conductive than PB-1 pipe, so will lose at least 1,800 times as much heat through the pipe.

Furthermore, PB-1 pipe has a thicker wall thickness in comparison to copper which further decreases the temperature loss through the pipe wall.

## Buteline Internal Bore Sizes

---

Pipe		Fittings	
Pipe Size	I.D. of Pipe (mm)	Fitting Size	I.D. of Fittings (mm)
10mm	6.9	10mm	4.55
16mm	12.1	16mm	9.60
22mm	17.1	22mm	14.40
28mm	22.2	28mm	18.05



## Pipe Wall Thickness

Due to the chemical properties of Polybutene-1 (PB-1) raw material, only Polybutene-1 (PB-1) piping can achieve high temperature and high stress but maintain lower wall thickness to ensure adequate water-flow through the pipe network.

Lower wall thickness also means a larger internal bore for a given external pipe diameter, resulting in reduced head pressure loss and lower flow speeds to deliver a fixed volume of water.

A comparison of the inside diameter / thickness of Polybutene-1 (PB-1) with other plastic materials is shown in the following graph:

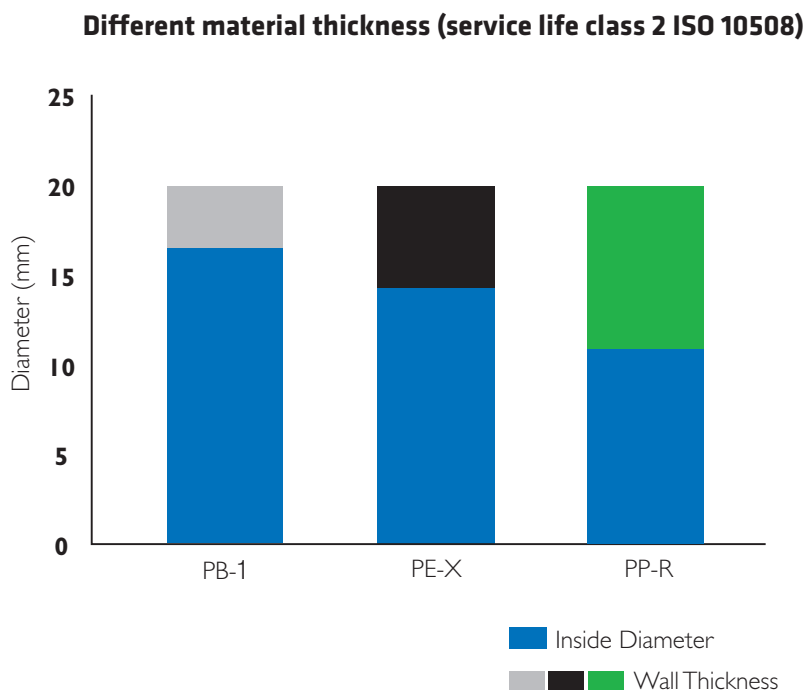

A more visual comparison can also be made using a series of cut-away diagrams:

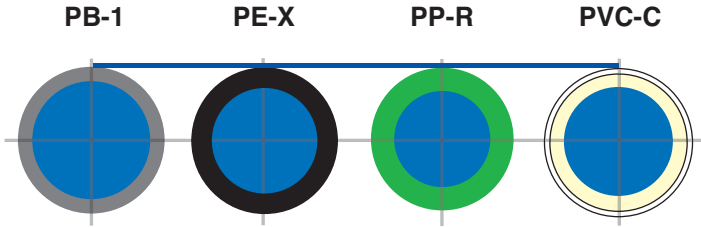

Buteline pipe sizes are similar to traditional metal pipe sizing, making size-for-size substitution possible. There is no need for upsizing, therefore Buteline pipe is an economical choice.

In addition to this, there is no scale build-up or corrosion with Buteline Polybutene-1 pipe.

### Flow Rates at Specific Velocities for PB-1 Pipe

Velocity	10PB Flow Rate	16PB Flow Rate	22PB Flow Rate	28PB Flow Rate
1.6m/s	0.37 L/min	11.8 L/min	23.4 L/min	37.9 L/min
2.4m/s	0.55 L/min	17.7 L/min	34.9 L/min	56.8 L/min
3.0m/s	0.68 L/min	22.1 L/min	43.8 L/min	71.0 L/min

## Working Temperature and Pressure

As stipulated in ISO 10508, the lifetime of Polybutene-1 (PB-1) pipe is 50 years and longer according to permissible working pressure / temperature.

Buteline Class 16 PB-1 Pipe

Temperature °C	Pressure		
	kPa	P.S.I.	Bar
20	1600	232	16.0
40	1370	198	13.7
60	1050	152	10.5
70	880	128	8.8
82	740	108	7.4

NOTE: These pressure/temperature combinations are maximum and should not be exceeded.

***Buteline PB-1 pipe has a maximum recommended everyday operating temperature of 82°C and it is not recommended for applications where the CONTINUOUS operating temperature may exceed this limit.***

***The Buteline plumbing system will operate at temperatures exceeding this limit (been tested and approved by WRAS to 95°C) and whilst this is not harmful to the system in the short term, it will prove detrimental to the long term performance of the Buteline PB-1 plumbing system and will greatly shorten the life expectancy of the entire system significantly below its intended design life.***

***As a responsible and transparent manufacturer, Buteline will not guarantee its PB-1 pipe and fitting system where the everyday operating conditions exceed 82°C and cause damage to the molecular structure of the polymers as a result of constant overheating.***

## Working Temperature and Pressure

Buteline recommends a safety valve be incorporated in all high pressure hot water systems

Temp. Pressure Relief Valve	Expansion Valve	Limiting Valve
7.0 Bar	5.5 Bar	3.5 Bar
8.5 Bar	7.0 Bar	3.5 Bar

*NOTE: Hot water storage cylinders with specification ratings of 1000 - 1400 kPa need to be valved as directly above.*

## Pipe Pressure Head Loss for Polybutene-1 Pipe

Pressure / Head Loss per 30 Metres (100 Feet) of Pipe

Minimum Flow Required	10mm	16mm	22mm	28mm
L/min	Bar	Bar	Bar	Bar
0.5	0.036	0.002	-	-
1	0.131	0.007	0.001	-
2	0.472	0.026	0.005	0.002
3	1.000	0.055	0.011	0.004
4	1.704	0.094	0.019	0.006
5	2.573	0.141	0.029	0.009
10	-	0.510	0.104	0.034
12	-	0.715	0.146	0.047
14	-	0.950	0.194	0.063
16	-	1.217	0.248	0.080
18	-	1.513	0.309	0.100
20	-	1.839	0.375	0.121
25	-	2.778	0.567	0.183
30	-	3.893	0.795	0.256
35	-	5.177	1.057	0.341
40	-	6.628	1.353	0.437
45	-	8.242	1.628	0.543

Please refer to page 48 for a Pressure Conversion Chart.

## Solar Hot Water

---

As solar hot water systems are an uncontrolled heat source, temperatures over 82°C are frequently experienced, therefore the Buteline Plumbing System must be installed in a manner to protect the system from excessive temperatures.

- (a) The Buteline Plumbing System is able to be connected to a solar heated storage cylinder outlet provided it is connected after an approved solar tempering valve only.
- (b) Do not use Polybutene-1 pipe for solar heater-to-cylinder plumbing.

## Hot Water Installations

---

- (a) Buteline PB-1 installations should have a minimum of 1 metre of copper tube from the hot water cylinder. When using a tempering valve, use Buteline PB-1 pipe direct from mixing outlet.
- (b) All installations supplying hot water that are to be utilised for personal hygiene require a tempering valve to be installed on the outlet side of the hot water cylinder. This ensures safe temperatures for the householder at the tap.
- (c) Instantaneous domestic water heaters do not require 1 metre of copper tube on the outlet. Buteline PB-1 pipe can be connected directly to the outlet.
- (d) Do not use Polybutene-1 pipe for a back boiler to cylinder plumbing as back boilers constantly exceed 82°C.
- (e) When commissioning the plumbing system, set and test the temperature of the hot water cylinder. Hot water cylinder thermostats should be set at a maximum of 60°C as part of the test procedure. With a setting of 60°C the hot water system can be maintained within operating requirements and a long service life is expected for the complete plumbing system.

## Oil Fired Boilers

---

The use of a polymer plumbing system in conjunction with an oil fired boiler, may or may not be suitable depending on the specific boiler and its normal operating working temperatures. The recommended maximum long term operating temperature of Buteline is 82°C and where an unsuitable boiler is used with Buteline, the Buteline Guarantee will not be applicable.

**PRIOR to any installation of the Buteline Plumbing System with an oil fired boiler, the installer MUST contact the boiler manufacturer gaining written confirmation that the specific boiler (quote model) proposed for installation is suitable for use with the Buteline PB-1 Plumbing System.**

Buteline recommends the installation of a pipe stat with all oil fired boilers to ensure any maximum working temperatures quoted by the boiler manufacturer are adhered to.

## Re-circulating Continuously Operating Ring Main Hot Water Systems

---

A continuously operated re-circulating system is a hot water supply system which provides hot water to outlets and incorporates all three of the following:

- Is maintained at a temperature above 60°C.
- Is replenished with an incoming water supply to replace the water drawn to outlets.
- Is a pumped, circulating system.

Continuously operated re-circulating systems are very different from conventional hot water supply and central heating systems found in domestic properties, for which our products have been tested to, under either BS 7291 2010 Class S or WRAS approval standards, and for this reason these products must not be used on any continuously operated re-circulating systems as they are not approved under the current version of these standards. Manufacturers own technical information should always be consulted as specific product limitations may apply.

## Is Buteline Suitable for use with Re-circulated Hot Water Systems?\*

\*Buteline will not advise installers on the suitability of their specific system, simply follow the flow chart below to gain your conclusion.

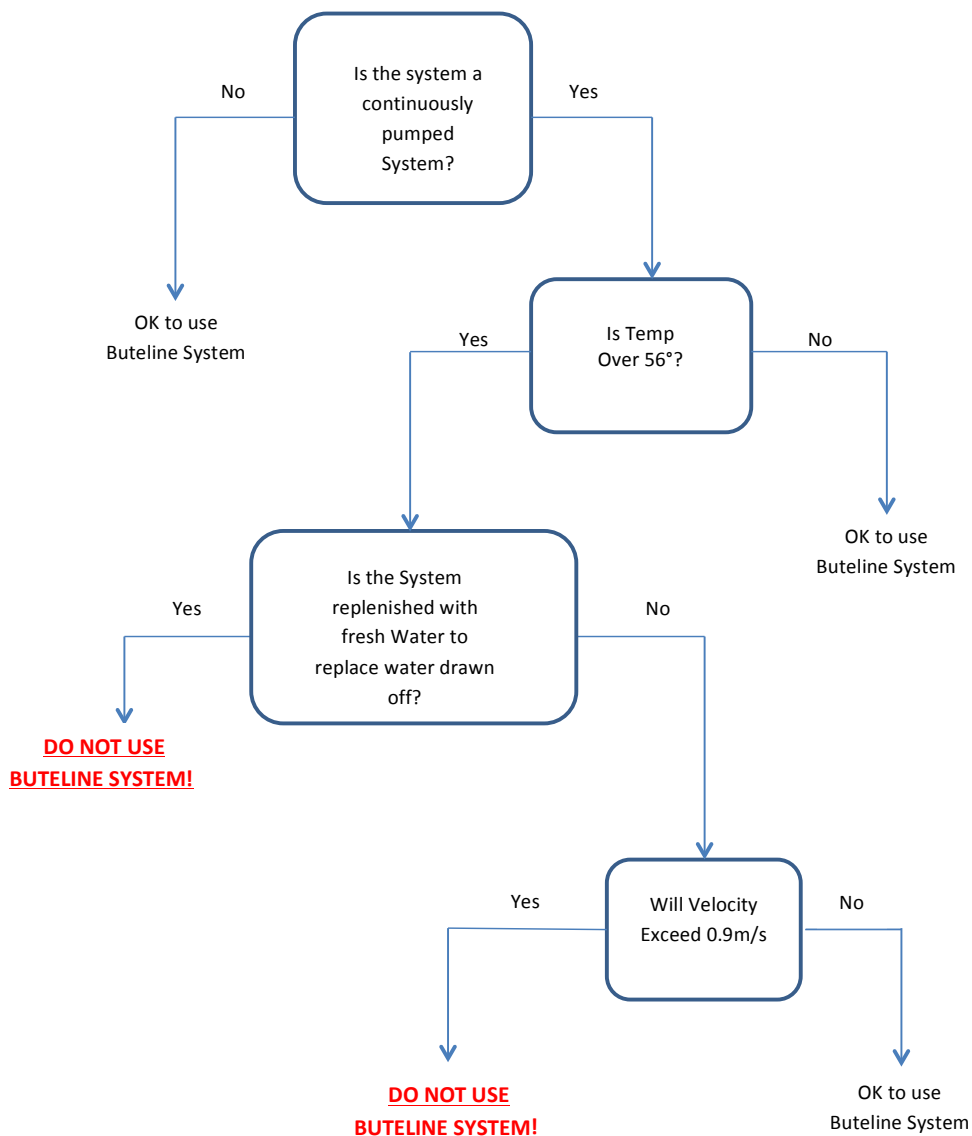

## Bute-1 Installation Guide

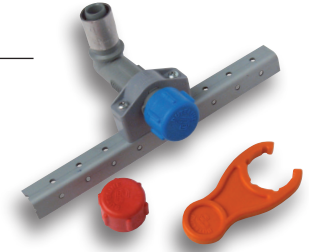

### Pipe Out Stage

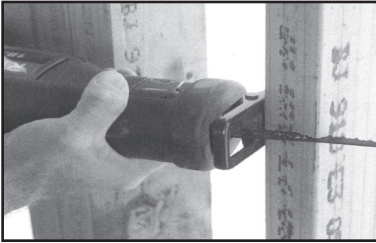

1. Cut 15mm deep slots into the full width of the timber studs with a wide saw blade (eg: wall board saw, reciprocating saw or circular saw).

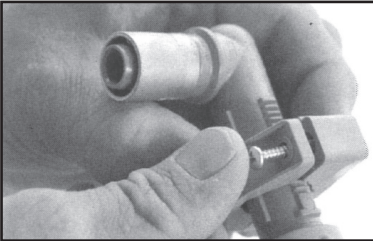

2. Assemble the Bute-1 by following the instructions enclosed in the box, clicking it together and then pushing the supplied screws through the holes to hold the assembly together. Then screw the assembled fitting to the angle brace.

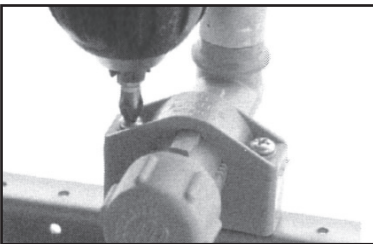

3. Tighten (nip) the Bute self-sealing protective test cap with the Bute palm spanner supplied. (No washers or thread tape etc. required). Fit pipe and clamp.



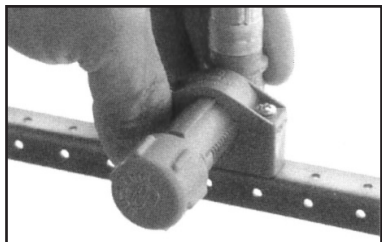

4. Pull the Bute-1 fitting into the fully forward position.

### Fit Off Stage

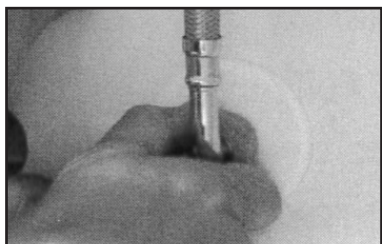

1. Remove the Bute self-sealing protective test cap with the Bute palm spanner and drain.
2. Fit wall flange (if necessary) and then connect the appropriate fitting and do not overtighten.
3. Push back the Bute-1 until contact is made with the wall lining.

## Testing Your Installation

---

As with all plumbing installations, Buteline PB-1 installations (10mm, 16mm, 22mm & 28mm) should be tested immediately after installation. Systems should be tested with COLD water.

**As a minimum requirement, you should pressure test the system at 10 bar for 1 hour or alternatively at 7 bar for 12 hours or overnight.**

Whilst Buteline recommends that our system only requires pressure testing once as outlined above, should a further “second fix” test be required for the purposes of testing any attached appliances (i.e Shower valves, Taps or General Brassware) we recommend that testing is carried out at 4 bar pressure for 1 hour.

Any secondary test carried out at the lower 4 bar pressure should only be executed AFTER the initial first test has been completed, and can't be used as a replacement for the first test procedure.

## Other Uses for the Buteline Plumbing System

---

If you wish to use the Buteline System outside of a normal potable water system (e.g. compressed air lines), please check with our Buteline technical representative for appropriate recommendations and installation instructions on 0800 043 8883 before you proceed to install.

## Use for Central Heating Applications

---

Due to the excellent flow characteristics and the similar sizing to copper piping, no special considerations need to be given to the use of the Buteline System when designing central heating systems. The Buteline PB-1 System complies with the requirements of BS7291:2002, and has been approved by WRAS as compliant to all the requirements for class S of the UK's regulators performance specification.

Please note that generally all the same installation requirements apply to the Buteline Plumbing System when used for central heating systems as to general hot and cold water plumbing systems.

Buteline can be used on the following:

- Mains fed and indirect cold water systems
- Vented and unvented hot water systems
- Vented and sealed central heating installations
- Underfloor heating

When installing direct to a central heating boiler Buteline recommends a minimum of 1m of copper pipe from the boiler unit to allow for conducted residual heat, unless otherwise stated in the manufacturers installation instructions.

***Buteline PB-1 pipe has a maximum recommended everyday operating temperature of 82°C and it is not recommended for applications where the CONTINUOUS operating temperature may exceed this limit.***

***The Buteline plumbing system will operate at temperatures exceeding this limit (been tested and approved by WRAS to 95°C) and whilst this is not harmful to the system in the short term, it will prove detrimental to the long term performance of the Buteline PB-1 plumbing system and will greatly shorten the life expectancy of the entire system significantly below its intended design life.***

***As a responsible and transparent manufacturer, Buteline will not guarantee its PB-1 pipe and fitting system where the everyday operating conditions exceed 82°C and cause damage to the molecular structure of the polymers as a result of constant overheating.***

## Frequently Asked Questions

---

Q: Is the Buteline Product in pack sizes?

A: *Most Buteline fittings are in packs of 10 or 25, Buteline Pipe is produced in 16mm, 22mm and 28mm sizes and is supplied in a variety of 25mtr, 50mtr, 100mtr and 20mtr coils or 3mtr straight lengths. Buteline also produces 10mm pipe in 100mtr coils for heating applications.*

Q: Can Buteline be installed when a Solar Heating system is used?

A: *Buteline cannot be used to connect the solar panels to the hot water storage unit and must only be connected to tempered lines.*

Q: Can Buteline be installed in concrete?

A: *Buteline can be installed in concrete providing the pipe is sleeved to allow free movement. Pipe work under concrete must not have any joints and must be in accordance with local Building Codes (plumber to check).*

Q: Can Buteline be installed in freezing conditions?

A: *Yes, the Buteline PB Plumbing System is the best choice in this situation as the PB pipe will absorb the expansion of frozen water within itself.*



Q: What is the maximum long term operation temperature?

A: *82°C at 7.4 Bar.*

Q: What bar pressure can it take and at what temperature?

A: *Please refer to and memorize the below table for 10mm, 16mm, 22mm, 28mm systems:*

Temp (°C)	20	40	60	82
Available Pressure (Bar)	16.0	13.7	10.5	7.4

***Buteline PB-1 pipe has a maximum recommended everyday operating temperature of 82°C and it is not recommended for applications where the CONTINUOUS operating temperature may exceed this limit.***

***The Buteline plumbing system will operate at temperatures exceeding this limit (been tested and approved by WRAS to 95°C) and whilst this is not harmful to the system in the short term, it will prove detrimental to the long term performance of the Buteline PB-1 plumbing system and will greatly shorten the life expectancy of the entire system significantly below its intended design life.***

***As a responsible and transparent manufacturer, Buteline will not guarantee its PB-1 pipe and fitting system where the everyday operating conditions exceed 82°C and cause damage to the molecular structure of the polymers as a result of constant overheating.***

Q: Does the Buteline Plumbing System need to be tested after installation?

A: *Yes only after installation, the Buteline Plumbing System requires to be tested at a standard cold temperature at 16 bar for 30 minutes and have no visible signs of leaks.*

Q: Can I reclamp a Buteline joint?

A: *Yes, providing Buteline installation guidelines are followed.*

Q: What material are the Buteline fittings made of?

A: *The polymer fittings are made from a high performance thermoplastic. The polymer fittings can withstand high temperatures and will not corrode. The aluminium is annealed (heat treated) and is also air force grade. The metal fittings are DR Brass.*

Q: Does the Buteline warranty / guarantee apply when other manufacturers pipes or fittings are used in conjunction with the Buteline System?

A: *No, the Buteline Guarantee covers installation only when the complete Buteline Plumbing System is used (pipe, fittings, clamp tools etc).*

Q: What is the smallest bending radius for Buteline PB pipe?

A: *Ten times the diameter of the pipe, example - 220mm for 22mm pipe.*

Q: How far away from the hot water cylinder can Buteline be connected?

A: *Installations are required to have a minimum of 1m copper between the heat source and Buteline.*

Q: Can Buteline fittings be re-used?

A: *No, once clamped the joint is permanent, the product is designed like this so that the fittings cannot be tampered with or incorrectly installed. A permanent joint leaves you and the customers with peace of mind.*

Q: Can other tools be used to clamp the fittings together?

A: *No, you must only use the Buteline clamp tool as it is specifically designed for the system.*

Q: Can Buteline be installed in direct sunlight?

A: *Yes, provided that the Buteline pipe is sleeved or painted (ideally with water based paint).*

Q: Can you connect Buteline to existing systems?

A: *Yes, we have connections to copper or push fit, but we will only guarantee the Buteline product.*

Q: Can Buteline be used for central heating and underfloor heating?

A: *Yes it can, the Buteline Plumbing System is suitable for all plumbing and heating applications including underfloor heating.*

Q: What standards and approvals does the Buteline Plumbing System meet?

A: *The Buteline Plumbing System meets all relevant UK approvals:*

British Standards – BS 7291:2002

National House Builders Council (NHBC)

WRAS 1702071

## Definition Of Terms

---

### “Back Boiler”

Water coils behind a domestic fire or cooking range. Any fuel fired unit fitted with a coil or tank system which permits water to heat and flow by convection to a storage cylinder.

### Boiling Point

The boiling point refers to the temperature at which a liquid changes to vapour by the addition of heat. The boiling point depends on the pressure at which the liquid is held. Boiling point increases as the pressure increases.

### Clamp

To brace, clasp or band for strengthening other materials. To strengthen or fasten to hold firmly. (Dictionary definition)

### Crimp

To press into pleats or folds. (Dictionary definition)

### Convection

Refers to the transfer of heat by means of a flow of fluid (liquid or gaseous form).

Liquid is heated in one place then moved to a place where it can give up its heat.

Natural convection is caused by heating a fluid making it less dense than the surrounding fluid and allowing the heated fluid to rise by displacement.

### Dezincification

When exposed to water many brasses show deterioration in which the zinc content is gradually removed – leaving a “spongy” copper which can become porous and leak. Some waters produce this effect very rapidly.



## Design Stress Pressure

A design stress pressure is a factor used to calculate test pressure or safe working pressure.

A formula is used which incorporates wall thickness, pipe diameter and material characteristics to determine acceptable pressures

i.e. Polybutene-1.

Design stress 1000 Bar = test pressure 240 Bar on 16mm pipe

(refer to Pressure Conversion Chart, page 48).

## Limiting Valve

A pressure limiting valve. A form of pressure reducing valve which automatically reduces inlet water pressure to acceptable limits at the outlet – but only when supply pressure exceeds the pre-set minimum.

## Potable

Drinkable.

## T.P.R. (Temperature/Pressure Relief)

A fixed setting combination valve for temperature and pressure relief.

## Pressure Conversion Chart

(Rounded)

kPa	Bar	Metre Head	P.S.I.
5	0.05	0.5	0.72
10	0.1	1	1.45
20	0.2	2	2.90
30	0.3	3	4.35
40	0.4	4	5.80
50	0.5	5	7.25
60	0.6	6	8.70
70	0.7	7	10.15
80	0.8	8	11.60
90	0.9	9	13.05
100	1.0	10	14.50
200	2.0	20	29.00
300	3.0	30	43.50
400	4.0	40	58.00
500	5.0	50	72.50
1000	10.0	100	145.00

### NOTES:

- 1 metre head = 3.28ft head
  - Additional conversions can be calculated.
- e.g. To find 700 kPa in bars or metre head from chart
- 500 kPa = 5 bar or 50 metre head
- + 200 kPa = 2 bar or 20 metre head
- = 700 kPa = 7 bar or 70 metre head

Did you know that we can design and supply **underfloor heating**?

**BUTELINE**  
PLUMBING SYSTEM

**COSY HOME**  
UNDERFLOOR HEATING SYSTEM

Heating Homes All Around The World

THE UK'S FINEST  
PLUMBING SYSTEM

WRAS  
APPROVED  
PRODUCT

BUTELINE  
GUARANTEE  
25

[www.buteline.com](http://www.buteline.com)

Email us at [ufh@buteline.co.uk](mailto:ufh@buteline.co.uk)  
or call us on 0800 043 8883 for more information.

## Project References



London City Island  
*Docklands, London*



Kidbrooke Village  
*Greenwich, London*



Smithfield Square  
*Hornsey, London*



New Capital Quay  
*Greenwich, London*



Pump Tower  
*Royal Victoria Dock, London*



Royal Arsenal Riverside  
*Woolwich, London*



Royal Connaught Park  
*Watford, Hertfordshire*

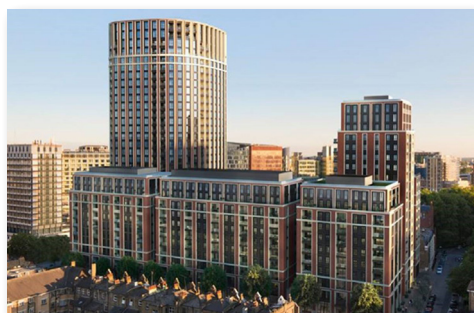

West End Gate  
*Marylebone, London*



Royal Winchester House  
*Bracknell, Berkshire*



Goodluck Hope  
*Docklands, London*

# The Evolution Of Plumbing...



In the UK for the past 10 years (and worldwide for over 30), the innovative Buteline clamp-seal system has been improving plumbers lives - **and their bank balances!** Don't get left behind, visit: [www.buteline.com](http://www.buteline.com) or call **0800 043 8883**



We guarantee it's the only change you'll ever want to make.

Scan this QR code >>>> to see the Buteline strength test demonstration

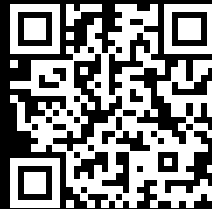

New to Buteline?  
Spend £350 &  
GET THE TOOLS  
**FREE!**\*

\*T&C's apply. Call us or ask your merchant for details.

## The Buteline Guarantee

---

### To whom it may concern,

Buteline UK Ltd warrants all of our pipes and fittings for 25 years from the date of manufacture against manufacturing defects, providing any installation of the Buteline Plumbing System is carried out by a suitably qualified plumber and installed in accordance to the guidelines set out in the current version of Buteline UK's Plumbing & Heating Installation manual.

Any claim made during the guarantee period subject to the above, where products are proven to be defective in materials and or manufacture then Buteline UK Ltd will supply replacement parts free of charge. This is the exclusive remedy under this guarantee.

This guarantee does not affect the statutory rights of a consumer.

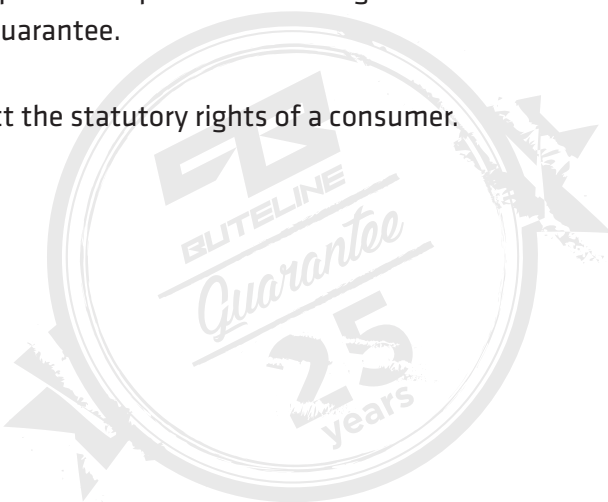

### Disclaimer

This manual is subject to amendment by Buteline UK Ltd and the latest available version is available from: <https://www.buteline.co.uk>. The users of this manual should ensure that their copy is the latest version available before proceeding with any installation. Incorrect installation of Buteline components made in accordance with an older version of the manual may invalidate any guarantee provided by Buteline UK Ltd. This manual is only a general guide to the Buteline™ Plumbing system and cannot take into account the different circumstances of every application.

The information contained in this manual is provided without any express, statutory or implied warranties. Neither the authors, Buteline, nor its partners or subsidiaries will be held liable for any damages caused or alleged to be caused either directly or indirectly by this manual.

## **Buteline UK Limited**

9 Swanbridge Industrial Park, Black Croft Road,  
Witham, Essex, CM8 3YN, United Kingdom

Phone: 01376 520792    Freephone: 0800 043 8883

Fax: 01376 520793    Email: [info@buteline.co.uk](mailto:info@buteline.co.uk)

[www.buteline.com](http://www.buteline.com)